



A powerful baler
for soft plastics

NP80P-II

NP80P-II is adapted for compacting expanding material and to manage its forces. These solutions provide a faster flow and heavier bale weight.

- ▶ Specialized for compacting large quantities of soft plastics, but handles most material
- ▶ High compaction pressure and generous feed opening on a minimum of floor space
- ▶ Convenient operating height
- ▶ Total height below 2 m
- ▶ Very reliable, proven long-lasting performance, even outdoors

New technique makes the NP80P-II even more efficient and simplifies operation:

Plug'n Press - the modern control system surveys starting up and operation

Autostart - the baler starts compacting automatically when closing the feed door.

Stay'n hold - the press ram stops in compaction mode (with full press power), giving even more compact bales. Suitable for materials that raise up after compaction. During the 'Stay'n hold' no electricity is needed!

Both 'Autostart' and 'Stay'n hold' can be switched on/off.



Our unique self-lubricating worm drive (no hydraulic oil) has been appreciated all over the world for more than 50 years. By a pallet truck all NP balers are easily located/relocated where they are needed the most. Overall, a sustainable solution for economy as well as environment!

Distinctness



The control system can easily provide additional features for customized solutions.

Efficiency



Six movable downholders keep the material down. This way even more material can be loaded.

Capacity

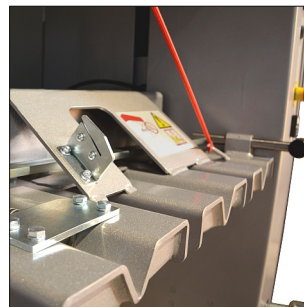

The press ram is especially adapted to compact plastics. A cutter for the straps is available on the press ram for easy tying of the bale.

Volume reduction



Built-in ejection of bale. The bale suits on a EUR-pallet. A volume reduction of up to 95%!



© Nättraby Verktygs AB

NP80P-II baler

- for large quantities of plastics -

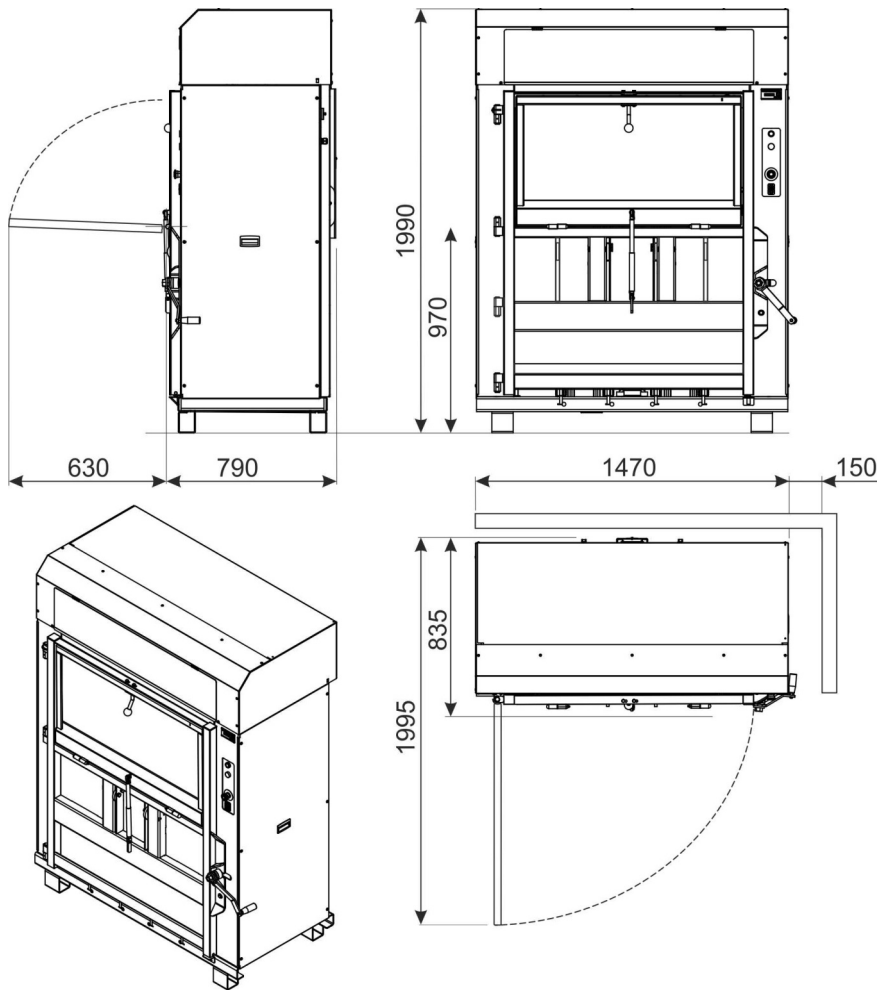

The feed door is opened 90° as standard but can be opened all the way down 180°, adjusted to your needs.



The main door of the NP80P-II can be fully opened (180°) so that the bale can be easily removed even in small spaces.



Our continuous development in close co-operation with users world wide gives us a unique knowledge of compacting and recycling.

The result is an outstanding range of products representing good design with excellent performance.

All compactors from NVA carry the CE-mark.



Since the mid-sixties more than 15,000 balers have been delivered all over the world.

Model	Pressure kN	Weight kg	Feed opening mm	Bale size mm			Bale weight kg	dB(A)
				Length	Width	Height		
NP80P-II	180	780	1100 x 550	1100	650	700-800	160 - 230	62

Voltage: 3-phase 400 V in standard version, other voltages available.

NP80P-II is one of the balers in our range - please contact us for more information of other products!

We reserve the right to introduce technical alterations.



Hagverk ehf

Stórhöfða 40, 110 Reykjavík

Símanúmer: 587-4760

Netfang: gudmundur@hagverk.is

www.hagverk.is